

LEGIONELLA RISK ASSESSMENT

Hot and Cold Domestic Water System

For

**Southampton Crematorium
Bassett Green Road
Southampton
Hampshire
SO16 3QB**

Prepared By

David Borthwick
Risk Assessor
Freeston Water Treatment Ltd
Unit 1 Lulworth Business Centre
Nutwood Way
Calmore Industrial Estate, Totton
Southampton SO40 3WW

20th March 2020



Southampton Crematorium

CONTENTS

PREFACE	Page 3 - 4
INTRODUCTION & LEGIONELLA CONTROL	Pages 5 - 12
SITE SURVEY COLD & HOT DISTRIBUTION	Pages 13 - 16
WATER TEMPERATURES	Page 17 -18
SHOWERS & ASSET REGISTER	Pages 19 - 21
GENERAL, ADDITIONAL PHOTOGRAPHS, DRAWINGS, EMERGENCY PROCEDURES & RECORDS	Pages 22- 31
CONTROL MEASURES, SUMMARY & REMEDIAL RECOMMENDATIONS	Pages 32 - 46
GLOSSARY OF TERMS	Pages 47 - 50
TERMS AND CONDITIONS	Page 51
LEGISLATION	Pages 52 – 53
RISK ASSESSOR QUALIFICATIONS AND RELEVANT EXPERIENCE	Page 54

PREFACE

Customer: Southampton City Council

Customer Address: Regional Business Centre
1 Guildhall Square
Southampton
Hampshire
SO14 7FP

Customer Contact: Lisa Huntriss
Telephone: 07500 994004

Site: Southampton Crematorium

Site Address: Bassett Green Road
Southampton
Hampshire
SO16 3QB

Site Contact: Dave Rees
Site Telephone: 02380 766405

Freeston Water Treatment Address:

Unit 1, Lulworth Business Centre
Nutwood Way
Calmore Industrial Estate
Totton
SouthamptonSO40 3WW

Telephone: 02380 669713
Fax: 02380 663825

Risk Assessment Consultant: David Borthwick

Date of Assessment: 20th March 2020

Date of Review: March 2022

MANAGEMENT STRUCTURE

Statutory Duty Holder: Not Appointed

Competent Person: Appointed

Deputy Competent Person: Appointed

INTRODUCTION & LEGIONELLA CONTROL

Southampton Crematorium is a medium sized building with two storeys.

During the course of the survey water systems within the building were risk assessed. These systems were chosen as being fully representative of the overall domestic water systems and outlets within the building.

The survey and risk assessment were undertaken in order to comply with the Health and Safety Executive requirements on the control and prevention of Legionellosis. The risk assessment has been carried out in accordance with ACoP L8:2013 - The control of Legionella bacteria in water systems (Approved Code of Practice and Guidance on Regulations), HSG274:2013 Legionnaires Disease: Technical Guidance and BS8580-1 2019 Water Quality – Risk Assessments for Legionella Control – Code of Practice.

The survey has been limited to the terms of reference agreed between Southampton City Council and Freeston Water Treatment Ltd. Observations relating to system conditions and other factors applicable to the requirements of ACoP L8, HSG274 and BS8580-1 have been recorded during the survey and specific references are made to compliance with the ACoP and the Technical Guidance in the Observations section of the report.

A Summary of Recommendations concludes the report. ACoP L8:2013 and HSG274 place responsibility on employers and others to prepare a scheme for preventing or controlling the risk from Legionellosis. Adoption of a monitoring scheme in conjunction with a regime of preventative maintenance and associated record keeping will meet these requirements.

Legionella Bacteria

- Legionellaceae are common environmental bacteria found in most natural water resources, including lakes and rivers. They can also survive water treatment processes in small numbers and can occur within mains water. Should these bacteria then enter any water service where they can multiply, and where a means of creating and transmitting water droplets is present, people using or in the vicinity of these services may be at risk.
- Infections caused by Legionella pneumophila bacteria or other organisms within the family Legionellaceae are termed Legionellosis. Legionnaires' disease is the worst of these and causes a pneumonia which can be fatal. Those most at risk are the very old and very young, the immunosuppressed and smokers etc.
- Legionella bacteria can also cause other, less harmful illnesses such as Pontiac fever and Lochgoilhead fever, which can affect all people.

The primary route of infection is caused by inhaling airborne water droplets that contain Legionella and are small enough to pass deep into the lung. It is also now believed that the disease can be contracted by inhaling Legionella bacteria following:

- Ingestion of contaminated water by susceptible individuals. It is rarely spread from person to person.
- The majority of individual cases or outbreaks of disease have been attributed to domestic water services within buildings which can cause a spray / aerosol e.g showers, toilets, taps, WCs and also evaporative cooling towers, whirlpool spas, swimming pools, irrigation water systems, vehicle washes etc.

Legionnaires' disease is most commonly caused by the inhalation of water droplets contaminated with the Legionella bacteria. It is therefore important that systems susceptible to colonisation by Legionella and which incorporate a potential means for creating and disseminating water droplets should be identified and the risk they present assessed.

A number of factors are required to create a risk of Legionellosis:-

- The presence of Legionella bacteria.
- Conditions suitable for the proliferation of those bacteria.
- A means of creating and disseminating an aerosol.
- The presence of individuals who may be exposed.

The conditions favouring the proliferation of Legionella are: -

- Moisture
- Temperature between 20.0°C and 45.0°C
- Availability of nutrients, for example, from sediment, sludge, organic material, scale, rust, compatible organisms and materials used in construction of water systems
- Presence of biofilm (bacterial slime) on surfaces in contact with water

The elimination of as many of these conditions as possible forms the basis of control of the risk. Treatment regimes to eradicate or reduce the proliferation of Legionella (based on physical or chemical disinfection of water systems) also help to control the risk but do not prevent it.

Under the ACoP, a suitable and sufficient assessment is required to identify and assess the risk of exposure to Legionella bacteria from work activities and water systems on the premises and any necessary precautionary measures.

Management Control

The Health and Safety Executive (HSE) highlights that poor management control and lack of record keeping can be major factors contributing to the inadequate control of Legionella bacteria. At all times there should be a documented Statutory Duty Holder, Competent Person, Deputies and a suitable communication pathway list.

All personnel involved with Legionella management should be suitably trained and competent. Refresher training should be undertaken as required.

A Written Scheme should be in place to ensure that all necessary controls and procedures are maintained, monitored and remain effective. The Risk Assessment does not involve the preparation of the written scheme but rather provides information that is critical to the preparation.

Regulations and guidance regarding the Written Scheme can be found in ACoP L8 Paragraphs 58-64.

The assessment was carried out on behalf of Southampton City Council.

- The employer, where the risk from their undertaking is to their employees or to other; or
- A self-employed person, where there is a risk from their undertaking to themselves or to others; or
- The person who is in control of the premises or systems in connection with the work where the risk is present from systems in the building (e.g. Tenants where the building is let. However, the landlord retains responsibility for its maintenance).

The assessment needs to be reviewed regularly and, in any case, whenever there is reason to believe that the original assessment may no longer be valid.

L8:2013 - The control of Legionella bacteria in water systems (Approved Code of Practice and Guidance on regulations), which was published by the Health and Safety Executive, highlights at paragraph 49 the importance of using competent service providers, it states;

“Those appointed to carry out the risk assessment and draw up and implement precautionary measures should have such ability, experience, instruction, training and resources to enable them to carry out their tasks competently and safely”.

Then at paragraph 57 it states;

“Duty holders should make reasonable enquiries to satisfy themselves of the competence of contractors in the area of work”

Paragraph 57 further states:

“An illustration of the levels of service to expect from Service Providers can be found in the Code of Conduct administered by the Legionella Control Association”

Freeston Water Treatment Ltd is registered with The Legionella Control Association (LCA). To be registered with the LCA a service provider has to agree to meet nine key service provider commitments and they are required each year, as evidence that they meet these commitments, to submit to the LCA secretariat an up to date statement of compliance. The statement should explain how the registering company complies with the nine commitments in terms of the Legionella control services that it provides.

Other Important Information

HSG274 Part 2 makes specific comments and recommendations regarding Thermostatic Mixing Valves – please note the extracts below: -

Section 2.74

TMVs are valves that use a temperature sensitive element and blend hot and cold water to produce water at a temperature that safeguards against the risk of scalding, typically between 38.0°C and 46.0°C depending on outlet use. The blended water downstream of TMVs may provide an environment in which legionella can multiply, thus increasing the risks of exposure.

Section 2.75

The use and fitting of TMVs should be informed by a comparative assessment of scalding risk versus the risk of infection from legionella. Where a risk assessment identifies the risk of scalding is insignificant, TMVs are not required. The most serious risk of scalding is where there is whole body immersion, such as with baths and showers, particularly for the very young and elderly, and TMVs should be fitted at these outlets. Where a risk assessment identifies a significant scalding risk is present, e.g. where there are very young, very elderly,

infirm or significantly mentally or physically disabled people or those with sensory loss, fitting TMVs at appropriate outlets, such as hand washbasins and sinks, is required.

The above recommendations mean that consideration should be given to removing TMVs where a scalding risk (as outlined above) is not significant. Where hot water temperatures are likely to be elevated it would be advisable to affix a Hot Water warning sign adjacent to the outlet.

Periodic Review

BS8580-1 2019 states that the Risk Assessment is an ongoing process which should be continually reviewed and updated as and when there are changes.

BS8580-1 2019 states that the original Risk Assessment should be formally reassessed when there are significant changes to ensure that it remains valid, for example, when there are:

- a) changes to the water system or its use;
- b) changes to the use of the building or part of the building in which the system is installed;
- c) changes to the availability of information about risks or control measures;
- d) indications that control measures are no longer effective;
- e) any of the factors in Clause 4; f) new construction works or system modifications planned;

or

- g) changes to the key personnel, contractors and service providers.

Where a reassessment has not been triggered by the above, there should be a policy of planned reassessment.

BASED ON THIS SURVEY IT IS OUR RECOMMENDATION THAT A REVIEW SHOULD BE CARRIED OUT AT A MINIMUM FREQUENCY OF 2 YEARS AT THIS SITE.

The risk assessment report relates to observations made and information supplied at the time of the survey. Every effort has been made to examine as much of the domestic water system as possible although some areas, such as pipework beneath floors or behind walls, would not have been inspected due to restricted access.

SITE SURVEY

The following section contains the condition survey reports for all water systems and associated plant located within the buildings premises. This includes where fitted:

- Cold Water Storage Tanks
- Calorifiers / Hot Water Cylinders
- Local Water Heaters <15 litres
- Local Water Heaters > 15 litres
- Showers
- Water Softeners
- Hot and Cold Water Distribution Temperatures
- Any Other Water Systems

Any points of note or results that are out of parameter are highlighted in red.

System Reference	Domestic Water Systems
Location	Southampton Crematorium
Method	Visual Assessment and Temperature Profiling

DOMESTIC HOT WATER STORAGE

There is no domestic hot water storage within Southampton Crematorium. All domestic hot water is provided by local water heaters.

Local Water Heaters

Hot water within Southampton Crematorium is by eight local water heaters. There is also an instantaneous water heater in the Staff shower room toilet.

The heater in the East Chapel Accessible toilet is a Santon type that has a cold water header tank. The header tank is moderately scaled and has corrosion evident. It is unknown when the header tank was last cleaned, I would recommend it is cleaned and disinfected and recorded within the logbook when this is carried out.

The other heaters are all mains fed self-contained units. The heaters in the west Chapel Staff Ladies and Gents toilets are behind screwed down panels that have fixtures attached to them. I was unable to access the heaters at the time of this assessment. I would recommend that these heaters are made accessible to enable servicing and temperature adjustment. At the time of this assessment the temperature of the heater in the Gents was low. I would recommend this is adjusted.

It is recommended in the ACoP L8 and HSG 274 part 2 that water heaters with no greater than 15 litres capacity should operate at 50° - 60°C.

COLD WATER STORAGE

There is no cold water storage within Southampton Crematorium, all cold water is supplied directly from the mains water service.

The incoming mains cold water supply temperature was:

10.8°C Satisfactory

WATER TEMPERATURES

In all areas of distribution and use, inspection, test and measurement were undertaken at representative positions in order to evaluate conditions and areas of potential risk.

At the time of the survey (within one minute) for hot water and (within two minutes) for cold water outlets in the building were recorded as follows: -

Location	Temperature °C			Comments
	Hot	Cold	Mixed	
Ground Floor Reception area Staff Toilet Wash Basin	57.8	11.0		Satisfactory
Ground Floor West Chapel Staff Gents Toilet Wash Basin	64.7	11.8		Satisfactory
Ground Floor West Chapel Staff Ladies Toilet Wash Basin	46.5	10.8		Not Satisfactory
Ground Floor East Chapel Ladies Toilet Wash Basin	58.4	11.2		Satisfactory
Ground Floor East Chapel Accessible Toilet Wash Basin	65.0	11.2	39.6	Satisfactory
Ground Floor Staff Room Kitchen Sink	61.6	10.2		Satisfactory

HSG274 Part 2 recommends hot water should achieve a minimum of 50.0°C at the outlet, or at the inlet to the Thermostatic Mixing Valve (TMV) if fitted within one minute.

Cold water should be stored and distributed at no more than 20.0°C and should be a maximum of 20.0°C within two minutes at the outlet.

The maximum hot water from an outlet fitted with a TMV should not exceed more than 46.0°C and should ideally be above 38.0°C.

SHOWERS

Showerheads and/or spray taps should be inspected on a quarterly basis (or as indicated by the rate of fouling) and cleaned and descaled if necessary.

Location	Lower Floor Staff Shower Room
Number of showerheads fitted	1
Type of showers?	1 x Mira Electric
Water Source Serving Showers?	Mains cold water
Are showers fitted with a TMV?	Yes – Integrated into shower control.
Are Showerheads Cleaned and Inspected?	Showerheads must be inspected and cleaned if required at least on a quarterly basis and recorded in the water systems logbook when carried out. The last recorded entry within the logbook for cleaning the showerhead was August 2019.
Shower risk rating	High due to aerosol creation
Are showers being used on a regular basis?	No

Showers are very high risk outlets as aerosols are created when operational and should have a good quality clean water source supplying them. It is essential that all showers are used on a regular basis; if showers are not used regularly then they should be flushed at least on a weekly basis for two minutes with the showerhead removed and recorded when carried out. If showers are not used, then consideration should be given into their removal ensuring no dead leg pipe work is created. Care should be taken when flushing showers.

ASSET REGISTER

Southampton Crematorium Domestic Water Asset Register		
Floor Level	Area	Asset Type
Outside	Outside	3 x Bib Taps
Ground	Reception Staff Toilet	1 x Wash Basin 1 x Toilet 1 x Water Heater
Ground	Cleaners Room	1 x Butler Sink 1 x Water Heater
Ground	West Chapel Staff Gents Toilet	1 x Wash Basin 1 x Toilet 1 x Water Heater 1 x supply to outside Tap
Ground	West Chapel Staff Ladies Toilet	1 x Wash Basin 1 x Toilet 1 x Water Heater
Ground	West Chapel Waiting Room Area	1 x Water Dispenser Machine
Ground	East Chapel Accessible Toilet	1 x Wash Basin 1 x Toilet 1 x TMV 1 x Water Heater

Floor Level	Area	Asset Type
Ground	East Chapel Gents Toilet	1 x Wash Basin 1 x Toilet 2 x Urinals
Ground	East Chapel Ladies Toilet	3 x Wash Basins 3 x Toilets 1 x Water Heater
Ground	East Chapel Waiting Room Area	1 x Water Machine
Ground	Bearers Room	1 x Drinks Machine
Ground	Staff Kitchen	1 x Sink 1 x Water Heater
Lower	Mess Room	1 x Sink 1 x Water Heater
Lower	Shower Room	1 x Electric Shower 1 x Wash Basin 1 x Toilet 1 x Instantaneous Water Heater
Lower	Plant Room	1 x Incoming Cold Mains

GENERAL

- Dead leg pipework are ideal areas for the proliferation of bacteria and should be removed or put on a weekly flushing regime (without creating an aerosol) and recorded within the logbook. Dead legs were found in the following areas:-
 - DL1-Ground Floor East Chapel Ladies Toilet – There is a dead leg on the far wall at low level. I suspect this to be from the hot flow pipe from the Accessible toilet
 - DL2-Lower Floor Messroom – There is a dead leg on the cold mains riser
- The accessible toilet in the East Chapel serves the accessible toilet wash basin and also the adjacent Gents toilet wash basins. The hot flow pipe work from the accessible toilet to the Gents toilet appears to continue on through to the adjacent Ladies toilet. The Ladies toilet is served by an independent local water heater and it would appear that the aforementioned hot flow pipe from the accessible toilet terminates in a dead leg at low level against the far wall. I would recommend this pipe work is investigated and any dead leg pipe work is removed.
- The header tank for the local water heater in the East Chapel accessible toilet is moderately scaled and is showing evidence of corrosion. I would recommend that the header tank is cleaned and disinfected and recorded within the logbook when carried out.

- The Local water heaters in the West Chapel staff toilets are located behind screwed down panels that have fixtures attached. I would recommend that that accessibility to these heaters is improved so that maintenance and routine monthly temperature monitoring and adjustment can be made. At the time of this assessment the temperature in the Gents toilet was not satisfactory. I recommend that this is adjusted.
- The drinks machines and the water dispenser have pressure reducers and inline filters fitted. It should be ensured that the machines are serviced, and filters changed as recommended by the manufacturers. Records of this should be kept filed within the logbook.
- All tap outlets within the buildings should be kept free of scale build up as this is an ideal nutrient for bacteria proliferation; clean on a regular basis. This should be recorded within the logbook when carried out.
- **All** infrequently used outlets should be flushed (without creating an aerosol) at least on a **weekly** basis for two minutes and recorded within a logbook when carried out. If these outlets are not required then I would recommend removal along with all associated pipework to prevent dead leg areas. This should also be recorded within the water hygiene logbook. No Flushing records were seen at the time of this assessment. I would recommend that all infrequently used outlets are flushed for at least two minutes weekly and recorded when done.
- Schematic drawings of the domestic water systems were seen to be filed within the logbook. All schematic drawings should be kept updated when changes are made to the water systems. Updated schematic drawings are included within this assessment.

- Domestic water samples for legionella testing have not been taken. I recommend that Legionella / Bacteriological water samples are taken for testing if temperatures fall outside of the limits as detailed in HSG274.
- I would recommend that Legionella training is undertaken for the required staff and training certificates be filed within the logbook.
- I would recommend that a Deputy Competent Person be nominated to carry out Legionella management duties during periods of holidays and absence and that they should be competent and fully trained in Legionella Management. All training certificates should be filed within the logbook.
- Monthly temperature monitoring of the hot and cold water outlets is being carried out and recorded and was seen to be up to date.
- The water temperatures of all sentinel (the nearest and furthest outlets from the domestic hot and cold water supplies) must be taken monthly and recorded. Other outlets should have temperatures taken on a monthly rotational basis so that over a period of 12 months a representative number of outlets will have been covered. If a TMV is fitted, then the temperature must be taken from the hot supply pipe immediately before the TMV.
- Flexible hoses were seen fitted within the building on wash basins, sinks etc. It should be ensured all flexible hoses are WRAS approved; change as required or hard plumb pipe work. This should be recorded within the logbook when carried out.

- The TMV in the East Chapel accessible toilet, although producing a satisfactory temperature, has been painted over and there are no records of it being serviced. Thermostatic mixing valves (TMVs) should be serviced and maintained in line with the manufacturer's recommendations and recorded within the logbook when carried out. It is not known if this is being carried out as no servicing records were seen filed within the logbook.
- An ACoP L8 / HSG274 compliant water services logbook produced by Southampton City Council is in place and all site staff who are involved in Legionella management have access. **All** legionella management should be recorded within it, e.g calorifier internal inspections / descaling and drain purging, sampling results, dead leg flushing, infrequently used outlet flushing, monthly calorifier and outlet water temperatures, annual cold water tank temperatures and cleaning and disinfections, Legionella training, tap and shower descaling etc.
- The management structure should be listed within the logbook with the names, contact details and responsibilities of the Statutory Duty Holder, the Competent Person and Deputy Competent Persons.
- There are runs of pipework that have no insulation. I would recommend that all pipework is insulated to minimise heat losses and gains.
- Showerheads and hoses should be cleaned and descaled on a quarterly basis or as indicated by the rate of fouling and recorded within the logbook when carried out. The last entry for cleaning the showerhead was in August 2019. I would recommend that quarterly cleaning and recording is resumed as soon as possible. If the shower is not used, then consideration should be given for the removal and associated pipe work also.

- Air conditioning units should be serviced and maintained as recommended by the manufacturers. Condensate and drip trays should be cleaned and disinfected on a regular basis. All servicing and cleaning should be recorded within the logbook when carried out.
- A Written Scheme was seen within the logbook to ensure that all necessary controls and procedures are maintained, monitored and remain effective. The Risk Assessment does not involve the preparation of the written scheme but rather provides information that is critical to the preparation. **Regulations and guidance regarding the Written Scheme can be found in ACoP L8 Paragraphs 58-64.**
- The Water systems logbook was last audited in November 2019. I would recommend that this is repeated on a quarterly basis.

ADDITIONAL PHOTOGRAPHS**P1****DL1****East Chapel Ladies Toilet**

Dead leg pipe work on Far Wall. Suspected from accessible toilet water heater hot flow.

**P2****DL2****Lower Floor Messroom**

Dead leg pipe work on the cold mains riser.

**P3****East Chapel Accessible Toilet**

Local Heater header tank shows moderate scale and corrosion.



P4**Drinks Machines**

Machines and inline filters should be serviced and changed as recommended by the manufacturers and recorded within the logbook when carried out.

**P5****Air Conditioning Units**

Air conditioning units should be serviced as recommended by the manufacturers. Condensate and drip trays should be cleaned and disinfected on a regular basis and recorded when carried out



EMERGENCY PROCEDURES

There was seen to be no documented emergency procedures in place relating to a possible outbreak of Legionnaires Disease at the time of this risk assessment; I would recommend emergency procedures be drawn up and put in place by referring to Appendix 2.3 and paragraphs 2.125–2.137 of HSG 274 part 2.

DRAWINGS

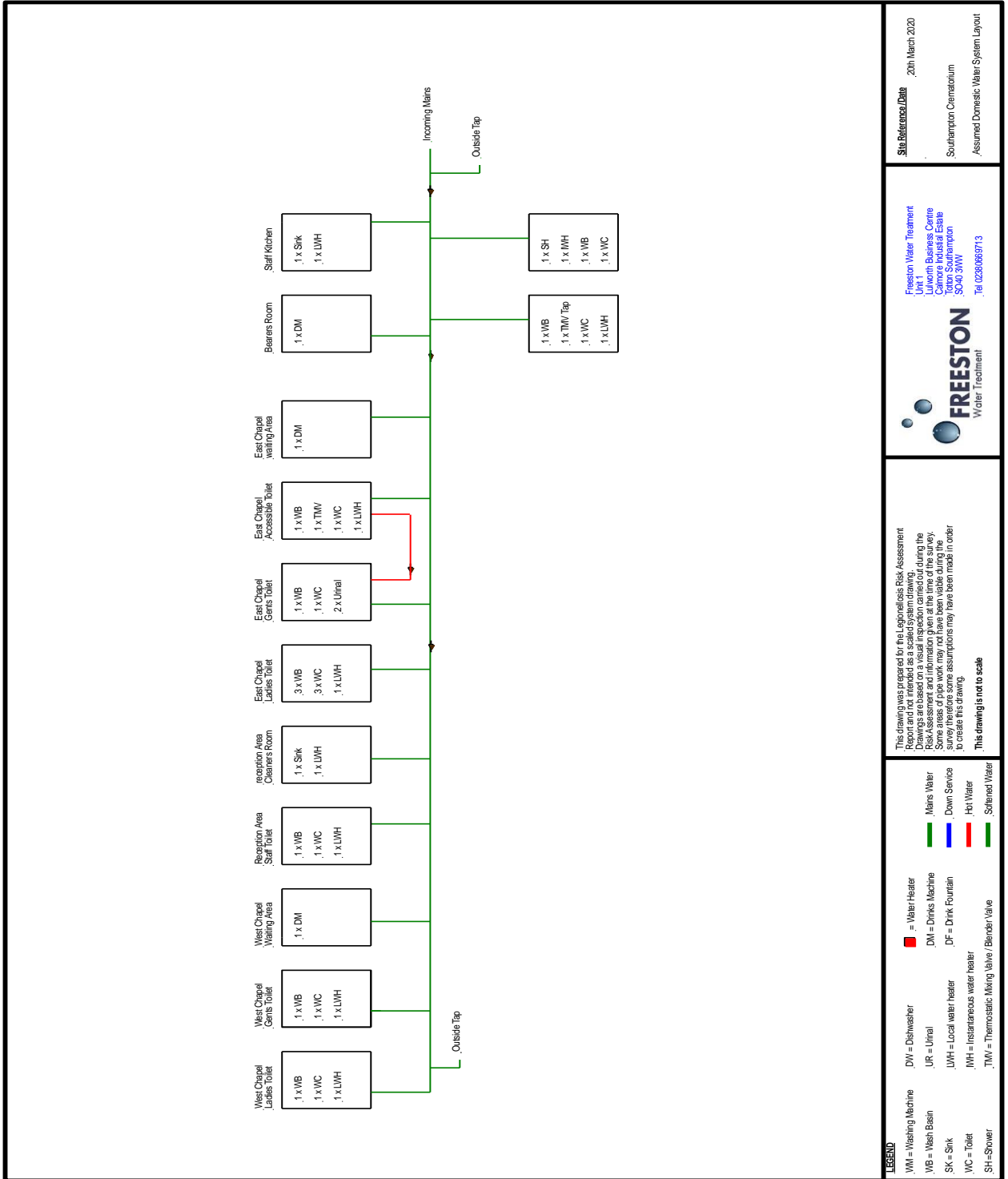

<p>FREESTON Water Treatment</p> <p>Freeston Water Treatment Unit 1 Culworth Business Centre Culworth Road Totton Southampton SO40 3WV Tel: 0238095713</p>	<p>Site Reference/Date Southampton Crematorium 20th March 2020</p> <p>Assumed Domestic Water System Layout</p>
--	--

RECORDS

An ACoP L8 / HSG274 compliant water services logbook should be put in place and include records of weekly, monthly, quarterly and annual procedures. These should be carried out as recommended in this risk assessment.

Details of the responsibilities held by the Duty Holder, Competent Person and Deputy Competent Person should be included together with items listed as follows:

Annual internal inspections of the calorifiers

Purging of the calorifiers

Annual inspections of the domestic cold water storage tanks

Cleaning and disinfection of the domestic cold water storage tanks

Audit sheet for inspections of the logbook and dated when completed.

Faults and defects to be recorded.

Flushing of all infrequently used outlets and dead legs (weekly).

Maintenance carried out on water systems

Monthly and annual temperature monitoring

Showerhead, hose and tap outlet cleaning and descaling

TMV Servicing and maintenance

All of the above should be included in the water systems logbook and signed for when completed.

HSG 274 CONTROL MEASURES TABLE 2.1 (where applicable)**Table 2.1:** Checklist for hot and cold water systems

Service	Action to take	Frequency
Calorifiers	Inspect calorifier internally by removing the inspection hatch or using a boroscope and clean by draining the vessel. The frequency of inspection and cleaning should be subject to the findings and increased or decreased based on conditions recorded	Annually, or as indicated by the rate of fouling
	Where there is no inspection hatch, purge any debris in the base of the calorifier to a suitable drain Collect the initial flush from the base of hot water heaters to inspect clarity, quantity of debris, and temperature	Annually, but may be increased as indicated by the risk assessment or result of inspection findings
	Check calorifier flow temperatures (thermostat settings should modulate as close to 60.0 °C as practicable without going below 60.0 °C) Check calorifier return temperatures (not below 50 °C, in healthcare premises not below 55.0 °C)	Monthly
Hot water services	For non-circulating systems: take temperatures at sentinel points (nearest outlet, furthest outlet and long branches to outlets) to confirm they are at a minimum of 50.0 °C within one minute (55.0 °C in healthcare premises)	Monthly
	For circulating systems: take temperatures at return legs of principal loops (sentinel points) to confirm they are at a minimum of 50.0 °C (55.0 °C in healthcare premises). Temperature measurements may be taken on the surface of metallic pipework	Monthly
	For circulating systems: take temperatures at return legs of subordinate loops, temperature measurements can be taken on the surface of pipes, but where this is not practicable, the temperature of water from the last outlet on each loop may be measured and this should be greater than 50.0 °C within one minute of running (55.0 °C in healthcare premises). If the temperature rise is slow, it should be confirmed that the outlet is on a long leg and not that the flow and return has failed in that local area	Quarterly (ideally on a rolling monthly rota)

Hot water services continued	All HWS systems: take temperatures at a representative selection of other points (intermediate outlets of single pipe systems and tertiary loops in circulating systems) to confirm they are at a minimum of 50.0 °C (55.0 °C in healthcare premises) to create a temperature profile of the whole system over a defined time period	Representative selection of other sentinel outlets considered on a rotational basis to ensure the whole system is reaching satisfactory temperatures for legionella control
POU water heaters (no greater than 15 litres)	Check water temperatures to confirm the heater operates at 50–60.0 °C (55.0 °C in healthcare premises) or check the installation has a high turnover	Monthly–six monthly, or as indicated by the risk assessment
Combination water heaters	Inspect the integral cold water header tanks as part of the cold water storage tank inspection regime, clean and disinfect as necessary. If evidence shows that the unit regularly overflows hot water into the integral cold water header tank, instigate a temperature monitoring regime to determine the frequency and take precautionary measures as determined by the findings of this monitoring regime	Annually
	Check water temperatures at an outlet to confirm the heater operates at 55–60 °C	Monthly
Cold water tanks	Inspect cold water storage tanks and carry out remedial work where necessary	Annually
	Check the tank water temperature remote from the ball valve and the incoming mains temperature. Record the maximum temperatures of the stored and supply water recorded by fixed maximum/minimum thermometers where fitted	Annually (Summer) or as indicated by the temperature profiling

Cold water services	Check temperatures at sentinel taps (typically those nearest to and furthest from the cold tank, but may also include other key locations on long branches to zones or floor levels). These outlets should be below 20.0 °C within two minutes of running the cold tap. To identify any local heat gain, which might not be apparent after one minute, observe the thermometer reading during flushing	Monthly
	Take temperatures at a representative selection of other points to confirm they are below 20.0 °C to create a temperature profile of the whole system over a defined time period. Peak temperatures or any temperatures that are slow to fall should be an indicator of a localised problem	Representative selection of other sentinel outlets considered on a rotational basis to ensure the whole system is reaching satisfactory temperatures for legionella control
	Check thermal insulation to ensure it is intact and consider weatherproofing where components are exposed to the outdoor environment	Annually
Showers and spray taps	Dismantle, clean and descale removable parts, heads, inserts and hoses where fitted	Quarterly or as indicated by the rate of fouling or other risk factors, e.g. areas with high risk patients
POU filters	Record the service start date and lifespan or end date and replace filters as recommended by the manufacturer (0.2 µm membrane POU filters should be used primarily as a temporary control measure while a permanent safe engineering solution is developed, although long-term use of such filters may be needed in some healthcare situations)	According to manufacturer's guidelines
Base exchange softeners	Visually check the salt levels and top up salt, if required. Undertake a hardness check to confirm operation of the softener	Weekly, but depends on the size of the vessel and the rate of salt consumption
	Service and disinfect	Annually, or according to manufacturer's guidelines
Multiple use filters	Backwash and regenerate as specified by the manufacturer	According to manufacturer's guidelines

Infrequently used outlets	<p>Consideration should be given to removing infrequently used showers, taps and any associated equipment that uses water. If removed, any redundant supply pipework should be cut back as far as possible to a common supply (e.g. to the recirculating pipework or the pipework supplying a more frequently used upstream fitting) but preferably by removing the feeding 'T'</p> <p>Infrequently used equipment within a water system (i.e. not used for a period equal to or greater than seven days) should be included on the flushing regime Flush the outlets until the temperature at the outlet stabilises and is comparable to supply water and purge to drain Regularly use the outlets to minimise the risk from microbial growth in the peripheral parts of the water system, sustain and log this procedure once started For high risk populations, e.g. healthcare and care homes, more frequent flushing may be required as indicated by the risk assessment</p>	Weekly, or as indicated by the risk assessment
TMVs	<p>Risk assess whether the TMV fitting is required, and if not, remove Where needed, inspect, clean, descale and disinfect any strainers or filters associated with TMVs To maintain protection against scald risk, TMVs require regular routine maintenance carried out by competent persons in accordance with the manufacturer's instructions.</p>	Annually or on a frequency defined by the risk assessment, taking account of any manufacturer's recommendations
Expansion vessels	Where practical, flush through and purge to drain	Monthly–six monthly, as indicated by the risk assessment

SUMMARY

At the time of this assessment it was seen that Legionella management is partially being carried out as required by HSG274 Part 2 Table 2.1 on pages 32-35 but needs to be improved and records kept more thoroughly of all Legionella management within the logbook.

Ensure that all recommendations within this report are read, understood and acted upon.

REMEDIAL RECOMMENDATIONS

Priority Rating	
	High priority issue - Urgent remedial action required to control a serious risk.
	Medium priority issue - Action is required in the near future to achieve compliance with ACoP L8/HSG274 standards/guidelines.
	Low priority issue - Minor action or remedial work that is beneficial, but may not be directly linked with compliance to ACoP L8/HSG274 standards/guidelines.

RECOMMENDATIONS

RECOMMENDATION						
Risk		HIGH	System	DOMESTIC WATER SYSTEMS		
Ref No	Photo No	Works	Comments:	Work Assigned To:	Date Completed	Residual Risk After Completion
1	1	DL1-East Chapel Ladies Toilet – There is a dead leg on the far wall. Dead leg pipe work is an ideal area for the proliferation of bacteria (including Legionella) and should be removed or flushed (without creating an aerosol) for at least two minutes at least on a <u>weekly</u> basis and recorded within the logbook when carried out.				Low

RECOMMENDATION

Risk		HIGH	System	DOMESTIC WATER SYSTEMS			
Ref No	Photo No	Works		Comments:	Work Assigned To:	Date Completed	Residual Risk After Completion
2	2	DL2-Lower Floor Messroom – There is a dead leg on the cold mains riser. Dead leg pipe work is an ideal area for the proliferation of bacteria (including Legionella) and should be removed or flushed (without creating an aerosol) for at least two minutes at least on a <u>weekly</u> basis and recorded within the logbook when carried out.					Low

RECOMMENDATION

RECOMMENDATION							
Risk		HIGH	System	DOMESTIC WATER SYSTEMS			
Ref No	Photo No	Works	Comments:	Work Assigned To:	Date Completed	Residual Risk After Completion	
3		There was seen to be no documented emergency procedures in place relating to a possible outbreak of Legionnaires Disease at the time of this risk assessment; I would recommend emergency procedures be drawn up and put in place by referring to Appendix 2.3 and paragraphs 2.125–2.137 of HSG 274 part 2.				Zero	
4		A Statutory Duty Holder, together with a Competent Person fully trained in Legionella Management duties, should be appointed. I would also recommend that a deputy Competent Person be nominated to carry out Legionella management duties during periods of holidays and absence and that they should be competent and fully trained in Legionella Management.				Zero	

RECOMMENDATION

RECOMMENDATION							
Risk		HIGH	System	DOMESTIC WATER SYSTEMS			
Ref No	Photo No	Works		Comments:	Work Assigned To:	Date Completed	Residual Risk After Completion
5		The management structure should be listed within the logbook with the names, contact details and responsibilities of the Statutory Duty Holder, the Competent Person and Deputy Competent Persons.					Zero
6		An ACoP L8 / HSG274 compliant water services logbook is in place and all site staff who are involved in Legionella management have access. All legionella management should be recorded within it e.g calorifier internal inspections / descaling and drain purging, sampling results, dead leg flushing, infrequently used outlet flushing, monthly calorifier and outlet water temperatures, annual cold water tank temperatures and cleaning and disinfections, Legionella training, tap and shower descaling etc.					Zero

RECOMMENDATION

RECOMMENDATION							
Risk		HIGH	System	DOMESTIC WATER SYSTEMS			
Ref No	Photo No	Works	Comments:	Work Assigned To:	Date Completed	Residual Risk After Completion	
7		The Written Scheme should ensure that all necessary controls and procedures are maintained, monitored and remain effective. The Risk Assessment does not involve the preparation of the written scheme but rather provides information that is critical to the preparation. Regulations and guidance regarding the Written Scheme can be found in ACoP L8 Paragraphs 58-64.				Zero	
8		I recommend that all relevant staff should undertake Legionella management training and certificates filed within the logbook when carried out.				Zero	

RECOMMENDATION

RECOMMENDATION							
Risk		MEDIUM	System	DOMESTIC WATER SYSTEMS			
Ref No	Photo No	Works	Comments:	Work Assigned To:	Date Completed	Residual Risk After Completion	
9		I recommend that domestic water samples are taken for Legionella / Bacteriological testing if temperatures fall outside of the limits as detailed in HSG274.				Low	
10		All tap outlets should be kept free of scale build up as this is an ideal nutrient for bacteria proliferation; clean on a <u>regular</u> basis. This should be recorded within the logbook when carried out.				Low	
11		Shower head and hose should be cleaned and descaled on a quarterly basis or as indicated by the rate of fouling. This should be recorded within the logbook when carried out.				Low	
12	4	Drink Machines and inline filters and strainers should be serviced and changed as recommended by the manufacturers. This should be recorded within the logbook when carried out.					

RECOMMENDATION

RECOMMENDATION							
Risk		MEDIUM	System	DOMESTIC WATER SYSTEMS			
Ref No	Photo No	Works	Comments:	Work Assigned To:	Date Completed	Residual Risk After Completion	
13		The local water heaters in The West Chapel Staff Toilets are located behind screwed down panels. I would recommend that access is made to enable easier servicing and temperature adjustments				Low	
14		The West Chapel Staff Gents Toilet local water heater had a low temperature. I would recommend the heater is adjusted to produce a satisfactory temperature.				Low	
15	3	The East Chapel Accessible Toilet local water heater header tank is moderately scaled and showing evidence of corrosion. I would recommend this is cleaned and disinfected and recorded within the logbook when carried out.				Low	

RECOMMENDATION

RECOMMENDATION							
Risk		MEDIUM	System	DOMESTIC WATER SYSTEMS			
Ref No	Photo No	Works	Comments:	Work Assigned To:	Date Completed	Residual Risk After Completion	
16		Flexible hoses were seen fitted. It should be ensured <u>all</u> flexible hoses are WRAS approved; change as required or hard plumb pipe work. This should be recorded within the logbook when carried out.				Low	
17		Ensure that all domestic hot and cold water pipework is adequately insulated against heat loss / gain.				Low	
18	5	Air conditioning units should be serviced and maintained as recommended by the manufacturers. Condensate and drip trays should be cleaned and disinfected on a regular basis. All servicing and cleaning should be recorded within the logbook when carried out.				Low	
19		Ensure the TMV Tap is serviced and maintained as recommended by the manufacturer and recorded within the logbook when carried out.				Low	

RECOMMENDATION

RECOMMENDATION						
Risk		LOW	System	DOMESTIC WATER SYSTEMS		
Ref No	Photo No	Works	Comments:	Work Assigned To:	Date Completed	Residual Risk After Completion
20		Schematic drawings of the domestic water systems were seen to be filed within the logbook. All schematic drawings should be kept updated when changes are made to the water systems.				Zero
21		Audit Logbook on at least quarterly basis.				Zero

GLOSSARY

This section contains the glossary of terms that may have been used within this documentation.

Aerosol	A suspension in a gaseous medium of solid particles, liquid particles or solid and liquid particles having a negligible falling velocity. In the context of this document, it is a suspension of particles which may contain legionella with a typical droplet size of <5 µm that can be inhaled deep into the lungs.
Algae	A small, usually aquatic, plant that requires light to grow.
Bacteria	(Singular bacterium) a microscopic, unicellular (or more rarely multicellular) organism.
Biocide	Substance which kills microorganisms.
Biofilm	A community of bacteria and other microorganisms embedded in a protective layer with entrained debris, attached to a surface.
Calorifier	An apparatus used for the transfer of heat to water in a vessel, the source of heat being contained within a pipe or coil immersed in the water
Chlorine	An element used as a biocide and for disinfection
Chlorine dioxide	A compound used as a biocide.
Cold water service	Installation of plant, pipes and fitting in which cold water is stored, distributed and subsequently discharged.
Contact time	The time a chemical is retained in the system.
Corrosion inhibitors	Chemicals which protect metals by: passivating the metal by the promotion of a thin metal oxide film (anodic inhibitors); or physically forming a thin barrier film by controlled deposition (cathodic inhibitors).

Dead end/blind end	A length of pipe closed at one end through which no water passes.
Dead leg	A length of water system pipework leading to a fitting through which water only passes infrequently when there is draw off from the fitting, providing the potential for stagnation.
Disinfection	The reduction of the number of microorganisms to safe levels by either chemical or non-chemical means (e.g. biocides, heat or radiation).
Distribution circuit	Pipework which distributes water from hot or cold water plant to one or more fittings/appliances.
Domestic water	Hot and cold water intended for drinking, washing, cooking, food preparation or other domestic purposes.
Fouling	Organic growth or other deposits on heat transfer surfaces causing loss in efficiency.
Hot water service	Installation of plant, pipes and fittings in which water is heated, distributed and subsequently discharged (not including cold water feed tank or cistern).
Legionnaires' disease	A form of pneumonia caused by bacteria of the genus legionella.
Legionella (plural legionellae)	A bacterium (or bacteria) of the genus legionella.
Legionellosis	Any illness caused by exposure to legionella.
Microorganism	An organism of microscopic size, including bacteria, fungi and viruses.
Neonates	New born children.
Nutrient	A food source for microorganisms.
Pasteurisation	Heat treatment to destroy microorganisms, usually at high temperature.

pH	The logarithm of the reciprocal of the hydrogen ion concentration in water, expressed as a number between 0 and 14 to indicate how acidic or alkaline the water is. Values below 7 are increasingly acidic, 7 is neutral, and values higher than 7 are progressively alkaline. However, acidity and alkalinity are not proportional to pH.
Planktonic	Free-floating microorganisms in an aquatic system.
Point of use (POU) filters	A filter with a maximal pore size of 0.2 µm applied at the outlet, which removes bacteria from the water flow.
Ppm	Parts per million) a measure of dissolved substances given as the number of parts there are in a million parts of solvent. It is numerically equivalent to milligrams per litre (mg/l) with respect to water.
Risk assessment	Identifying and assessing the risk from Legionellosis from work activities and water sources on premises and determining any necessary precautionary measures.
Scale inhibitors	Chemicals used to control scale. They function by holding up the precipitation process and/or distorting the crystal shape, thus preventing the build-up of a hard adherent scale.
Sentinel taps	For hot water services – the first and last taps on a recirculating system. For cold water systems (or non-recirculating HWS), the nearest and furthest taps from the storage tank. The choice of sentinel taps may also include other taps which represent parts of the recirculating system where monitoring can aid control
Sero-group	A sub-group of the main species.
Sessile	Aquatic microorganisms adhering to a surface, normally as part of a biofilm.

Shunt pump	A circulation pump fitted to hot water service/plant to overcome the temperature stratification of the stored water.
Slime	A mucus-like exudate that covers a surface produced by some microorganisms.
Sludge	A general term for soft mud-like deposits found on heat transfer surfaces or other important sections of a cooling system. Also found at the base of calorifiers and cold water storage tanks.
Stagnation	The condition where water ceases to flow and is therefore liable to microbiological growth.
Strainers	Coarse filters usually positioned upstream of a sensitive component, such as a pump control valve or heat exchanger, to protect it from debris.
Thermal disinfection	Heat treatment to disinfect a system.
Thermostatic mixing valve	A mixing valve in which the temperature at the outlet is pre-selected and controlled automatically by the valve.
Total viable counts (TVC)	The total number of culturable bacteria (per volume or area) in a given sample (does not include legionella).
Wholesome water	Water supplied for such domestic purposes as cooking, drinking, food preparation or washing; or supplied to premises in which food is produced

If any further information is required, please feel free to contact Freeston Water Treatment Ltd, or the surveyor responsible for the works on your site.

TERMS AND CONDITIONS

This assessment is based on information known to Freeston Water Treatment Ltd on the date of survey. Freeston Water Treatment Ltd accepts no responsibility for any loss or claim arising from information contained within this or any other associated document; “All our Risk Assessors are fully trained and competent to carry out Legionella Risk Assessments”.

Freeston Water Treatment Ltd reserve the right to allow our client fourteen days in which to notify Freeston Water Treatment Ltd of any inaccuracies contained within this documentation or changes that should be made, after which it will be assumed that our client has accepted the documentation to be satisfactory and fully complete.

Freeston Water Treatment Ltd rights reserved. No part of the format and content of this documentation may be reproduced, stored in a retrieval system or transmitted, in any form or by any means, electronic, mechanical, photocopying, recording or otherwise, without the prior written permission of Freeston Water Treatment Ltd.

In accordance with ACoP L8 (2013), Paragraph 47 – The Risk Assessment must be reviewed regularly and/or whenever there is reason to believe that the original assessment may no longer be valid.

We cannot guarantee that all pipework passing underground or through floors, walls and ceilings has been traced, and it is possible that certain system dead-ends or dead legs may not have been identified. As a result any schematic diagram(s) contained within this report only detail the visible or assumed pipework.

Whilst every effort has been made to ensure the accuracy of the content of this document, Freeston Water Treatment Limited will accept no responsibility for any omissions.

LEGISLATION

Health and Safety at Work etc. Act 1974

This Act is concerned with health, safety and welfare in connection with work and those people who may be affected by it. The act is primary legislation under which the Secretary of State makes specific regulations affecting the control of Legionellosis.

Management of Health and Safety at Work Regulations 1999

The regulations provide a framework for managing health and safety at work including the requirement for risk assessments and the establishment of appropriate management systems and procedures.

Control of Substances Hazardous to Health Regulations 2002 (as amended)

The aim of the Control of Substances Hazardous to Health (COSHH) Regulations 2002 is to protect persons who may be affected by hazardous substances present in the workplace. This includes both chemical and biological agents. The employer has to assess the risk from such substances, and for certain substances he has to measure the employees' exposure to them.

Reporting of Injuries, Diseases and Dangerous Occurrences Regulations 2013 (RIDDOR)

While Legionnaires' disease as such is not a notifiable disease under public health legislation (except in Scotland), it is reportable under RIDDOR if it could have been contracted in the workplace.

Notification of Cooling Towers and Evaporative Condensers Regulations 1992

These regulations require all premises containing a cooling tower or evaporative condenser to notify the local authority in whose area the building is situated. A form is available from the Environmental Health Department of the local authority. Notification must also be given of changes to the information supplied. It is however inspectors of the Health and Safety Executive who police the safe operation of cooling towers.

Water Supply (Water Fittings) Regulations 1999

These regulations are not directly concerned with the Legionellosis hazard, but govern the design, construction and use of materials in water systems. In particular they cover: -

- Backflow protection, i.e. the use of air gaps and not-return valves to protect the supply.
- The maintenance of water quality, e.g. tank design for hot and cold water services.
- The use of materials, i.e. those that do not promote bacterial growth.
- Water conservation, i.e. prevention of leakage.

RISK ASSESSOR QUALIFICATIONS & EXPERIENCE

TRAINING DESCRIPTION	BY WHOM	DATE
RESPONSIBLE PERSON – LEGIONELLA MANAGEMENT	HYDROVIRON	SEPT 2013
TMV MAINTENANCE	HORNE ENGINEERING	SEPT 2013
LEGIONELLA COOLING TOWERS AND AIR CONDITIONING	CITY AND GUILDS	SEPT 2013
RISK ASSESSMENT OF WATER SYSTEMS IN BUILDINGS	CITY AND GUILDS	SEPT 2013

Over 40 years' experience in domestic, commercial, oil, water, chemical and power station pipework and systems before training as a Risk Assessor.

Employed full time as a Risk Assessor with Freeston Water Treatment Limited since 2013.

Signed:



Risk Assessor

Freeston Water Treatment Ltd

Report Checked by:



Quality Manager

Date: 24 March 2020